

产品尺寸图 (DIMENSION)

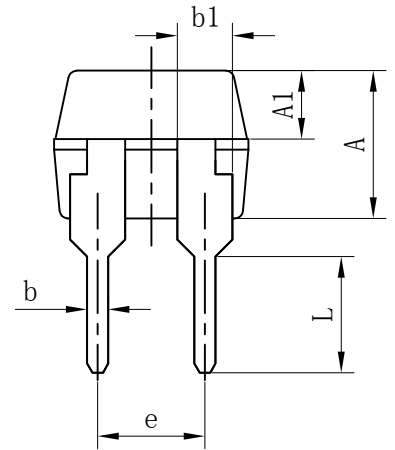
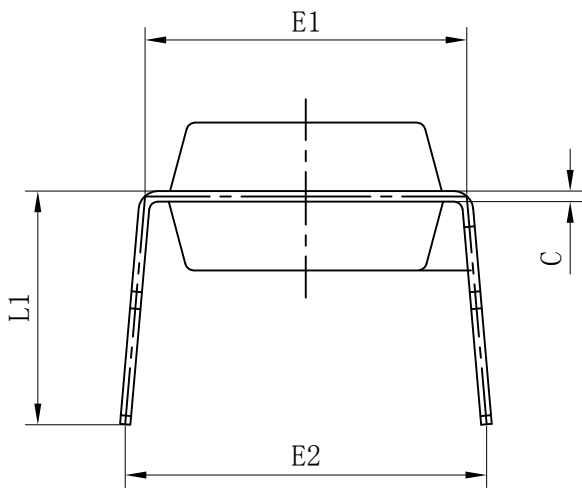
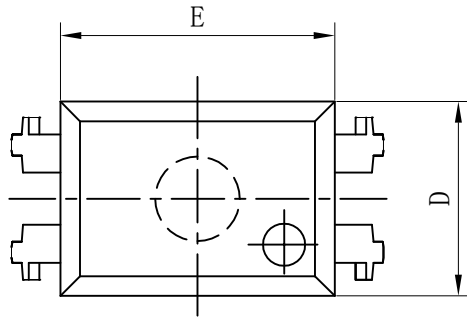

symbol	Dimensions In Millimeters			Dimensions In Inches		
	Min	Nom	Max	Min	Nom	Max
A	3.20	3.50	3.80	0.126	0.138	0.150
A1	1.42	1.62	1.82	0.056	0.064	0.072
b	0.47	0.50	0.53	0.018	0.019	0.020
b1	1.25	1.30	1.35	0.049	0.051	0.053
C	0.20	0.25	0.30	0.008	0.010	0.012
D	4.40	4.60	4.80	0.173	0.181	0.189
E	6.30	6.50	6.70	0.248	0.256	0.264
E1	TYP. 7.62			TYP. 0.300		
E2	8.26	8.56	8.86	0.325	0.337	0.349
e	—	2.54	—	—	0.100	—
L	2.70	2.75	2.80	0.106	0.108	0.110
L1	5.53REF			0.218REF		

FSMC

图名 NAME	DIP-4/DIP-4C		图号 DWG. NO.	DD0061	SH 1 OF 1
材质 MATERIAL	SPCE/LY65		REV.	C	
单位 UNITS	mm [INCH]	核准 APPROVE	审核 CHECKED	制图 DRAWN	 第三角法
日期 DATE	2019-08-07				
比例 SCALE	N. T. S.				

11-3001
01-01